

Verification of electrical safety testers: A better approach

Application Note



Instrumentation to test the safety of electrical installations, appliances, machines and electrical/electronic devices is becoming more prevalent, driven by new regulatory standards designed to protect users from electrocution and fire hazards. Examples of mandatory, annual testing standards are the UK BS 7671/16th Edition and the German equivalent, VDE 0100. Both ensure safety compliance in commercial and residential electrical installations. Other standards, like EN 60601/60335/60950/61010 and VDE 0700, are designed to ensure the safety of electrical appliances and machines. Other types of safety compliance testing are done in the final stages of electronic device manufacturing to ensure product safety and robustness, to comply with standards like CE. As these standards have become mandatory in numerous countries throughout the world, electrical safety tests are becoming commonplace as test specialists, technicians and production engineers need to demonstrate that installations, appliances and devices conform to strict government or test body standards. The instrumentation used to make these tests fall into a number of categories: Insulation resistance testers, installation testers, portable appliance testers (PATs), earth resistance testers, ground bond testers, hipot testers and electrical safety analyzers. They are used in a variety of applications including manufacturing, plant maintenance and routine service by test engineers, technicians, test specialists and electrical contractors.

In the past, it has been a challenge for metrologists to properly verify electrical testers' performance, especially for those testers with high voltages, high currents and extreme resistance measurement capability. This application note describes the functionality of some of the electrical testers, and discusses requirements to verify their performance. It also covers an improved method of verifying many of these devices and the challenges the design engineers faced when building these techniques into a new calibrator.

Electrical safety testers

There are many varieties of electrical safety testers in the marketplace today, spanning a wealth of applications that check aspects of electrical safety and reliability. As shown in Figure 1, the testers come in all shapes and forms, presumably optimized for their specific function. Each application has specific requirements, which most likely led to the plethora of industrial designs for the testers!



Figure 1. Electrical testers provide a wide variety of functions, and come in many shapes and sizes.

Testers are used in four common applications:

1. Verifying the safety and reliability of electrical installations.
2. Maintaining electrical equipment, such as electric motors, generators, wiring and transformers.
3. Type testing as well as annual verification of electrical apparatus to ensure proper grounding, leakage currents, and insulation.
4. Production testing of electrical appliances to ensure proper grounding and insulation.

Fluke Corporation undertook the challenge of designing a calibrator specifically for electrical safety testers. Unlike the more general purpose instruments that Fluke calibrators are traditionally known for, electrical safety testers posed design challenges because of their unique functionality and a much broader range of voltages, resistances and currents. The testers perform functions like touch and substitute leakage tests, RCD trip verification, loop/line impedance tests and high voltage insulation tests; none of which are supported in conventional dc and low frequency ac calibrators. The biggest issue is that the testers can source very high voltages and currents. For example, voltage signals coming from the testers

often times exceed 10 kV. They are capable of measuring up to 10 T Ω . Currents sourced are up to 30 A, with fault currents calculated up to 50 kA.

Generally, the tests performed by electrical testers can be classified by eight different functions:

1. Earth resistance (3-pole and 4-pole)
2. Ground bond resistance
3. Continuity
4. Insulation resistance
5. High voltage dielectric breakdown
6. Leakage current (earth, direct/touch, differential and substitute)
7. Loop and line impedance
8. Residual current device verification

Multifunction installation testers, portable appliance testers (PATs) and multifunction hipots (electrical safety analyzers) combine several of the previously listed tests into one instrument.

It is beyond the scope of this application note to cover all eight categories of testing and the unique difficulties each posed in terms of designing a calibrator to meet those requirements. This application note describes the functionality of four of the more challenging testers and their subsequent calibration requirements, from the perspective of calibrator designers.

Insulation resistance testers

Insulation testers, commonly called megohmmeters or Meggers[®] are used throughout the world to measure the insulation resistance of generators, motors, power transformers, wiring installations, appliances and other electrical apparatus like control, signal, and communications and power cables. They are often used in a routine maintenance program to chart the insulation resistance of a motor, over months or years. A large change in insulation resistance may be an indication of pending failure. This, then, leads to periodic calibration of the megohmmeter, to ensure the meter itself is not changing with time.

In the simplest sense, a megohmmeter measures resistors using Ohm's Law by stimulating the device or network with a voltage and then measuring the resultant current. The ideal calibrator for megohmmeters would consist of a wide variety of selectable resistors not much different than what a modern calibrator can provide with its synthesized resistance function. Where a megohmmeter calibrator differs from dc and low frequency calibrators is the range of resistances needed, and the voltage handling capability required. These electrical testers implement their resistance measurements at a much greater voltage than traditional ohmmeters found in digital multimeters (DMMs), for example. Megohmmeters utilize voltages, typically ranging from 50 V up to 5 kV. A typical DMM uses voltages less than 10 V. The larger voltages are required to measure the span of resistances needed for insulation testing, with upper ranges of 10 TΩ.

Nearly all insulation testers use dc for the stimulus voltage, so there are few ac requirements for the megohmmeter calibrator. Many of the megohmmeters are two terminal devices, that source a voltage and measure the resulting current determined by the device under test. Megohmmeters that measure 1 TΩ and above typically have a third terminal, called the guard, which is useful for eliminating leakage paths and other parallel elements from the measurement of the unknown resistance R_x . The purpose of the guard is to selectively null out parasitic resistive elements by cancelling currents that would normally flow through them, as shown in Figure 2^[1].

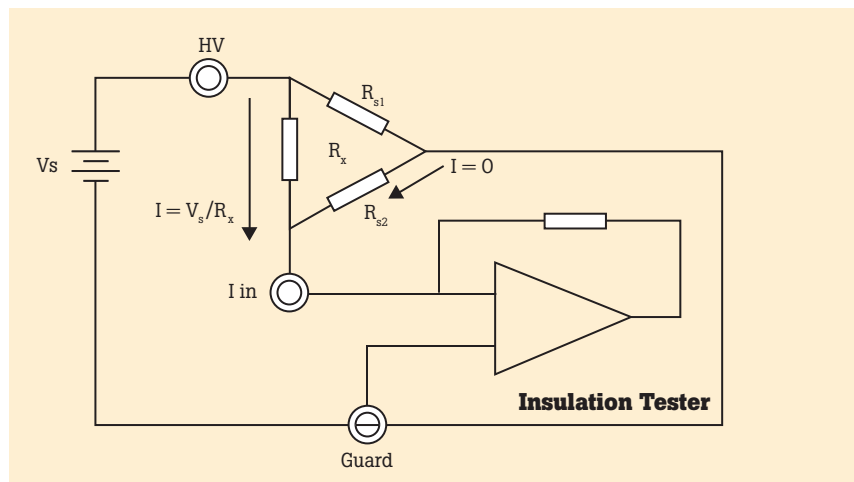

Figure 2. The guard maintains zero volts across R_{s2} , giving no current flow. All of the stimulus current flows through R_x , as desired.

A major issue in calibrating these devices is to find suitable resistors that are, of course, accurate enough; but also that are large enough in resistance value, and can withstand the high dc voltages. Furthermore, megohmmeter manufacturers have not standardized on any particular resistance value to calibrate them; hence a wide range of resistance values are required. A brief look at various insulation testers indicates they require differing performance checkpoints; for example, 50 kΩ on one tester, 60 kΩ on another, 100 kΩ on another, and so forth.

“General purpose” multifunction electrical/electronic calibrators cannot be used to calibrate insulation resistance testers, because their resistors typically can handle only a limited voltage, such as 20 V maximum. The challenge in designing a calibrator for insulation resistors is to incorporate their special requirements into a cost effective, compact and transportable solution.

Synthesized resistance methods were ruled out, because the high-voltage requirements would have made the design cost and size prohibitive. Instead, a matrix of discrete, high-voltage resistors was placed into a clever array where more than 500,000 resistance outputs are available. In this calibrator, there are eight ranges of resistance values, spanning from 10 kΩ to 10 GΩ, each with 4.5 digits of settable outputs.

Gathering the proper high-voltage resistors and putting them into one box had other challenges. There were safety challenges associated with the *Low Voltage Directive*, a mandatory requirement for the European CE mark. The relevant standard for instruments manufacturers is EN 61010—*Safety Requirements for Electrical Equipment for Measurement, Control and Laboratory Use*^[2]. Limiting the calibrator voltage to 1,000 V_{rms} yields a design that is within the guidelines of the *Low Voltage Directive*. How then are

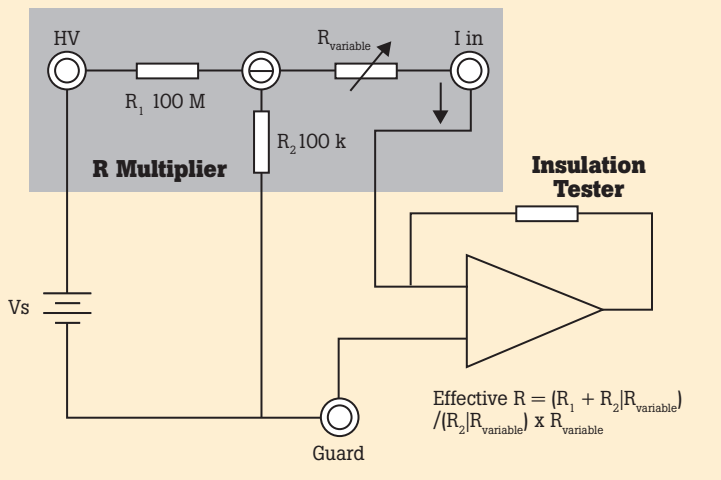

Figure 3. With Rvariable set to 100 MΩ, the effective resistance the megohmmeter reads is 1000 times higher, or 100 GΩ.

the megohmmeters that utilize voltages up to 5 kV calibrated? These instruments have wider dynamic range, measuring up to 10 TΩ, and have the guard terminal described above, which allows them to make accurate measurements at the very high values. Fortunately, such a guard configuration lends itself to a resistance multiplier that can effectively multiply a known resistance by 1000, as shown in the example of Figure 3^[3]. Equally as important, since the multiplier is a separate, isolated, standalone box, the high-voltage requirements for this multiplier can be met, falling outside the scope of the *Low Voltage Directive*.

Earth resistance testers

Another category of safety testers that posed unique challenges are the earth resistance testers. These testers are used by electricians to check the adequacy of the actual grounding system in power-generating stations, electrical-distribution systems, industrial plants, telecommunication systems, and lightning arrester installations. They too operate utilizing Ohm's Law. They come in three or four pole configurations, with the three-pole earth resistance tester being the most common.

The resistances measured at various points are not linear with distance, as there are multiple dimensions that make up the earth resistance. A proper earth ground installation, and the proper verification of such an installation, requires that a resistance vs. distance graph be made. The earth resistance of an installation is the resistance that is 62 % of the distance from Rod 1 to Rod 3. Such a graph is shown in Figure 5.

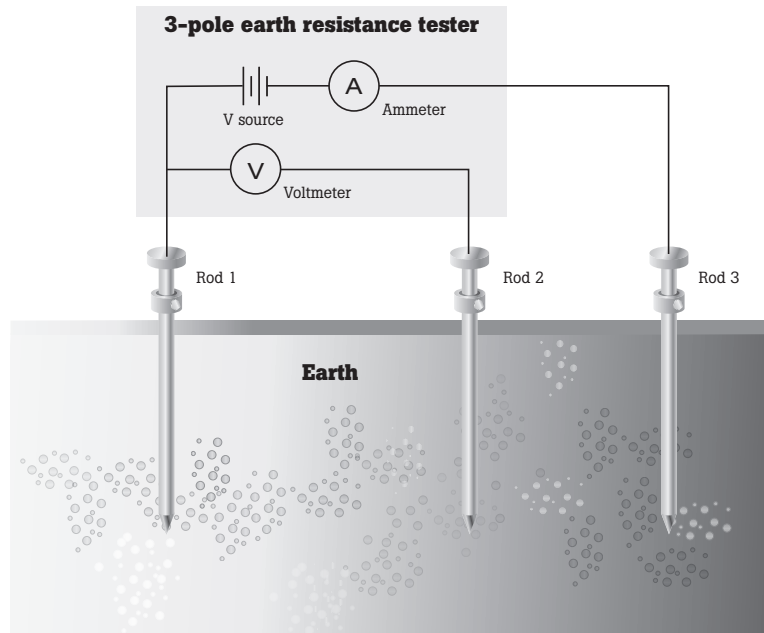

Figure 4. A 3-pole tester works by providing a known current through an earth path, from Rod 3 to Rod 1. In the fall-of-potential resistance test, the resulting voltage is measured at various points of the path back to the electrode being tested.

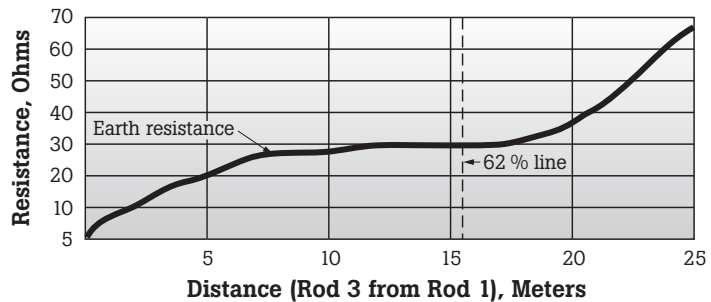

Figure 5. Earth resistance is plotted by moving Rod 2 from near Rod 3 towards Rod 1. In a proper test, the resistance at the 62 % point should be in the flat region as shown.

The challenge from a calibrator designer's perspective was to provide a large array of resistors that can handle the high ac currents these testers provide, up to 400 mA; and to provide enough resistance values, which will adequately check the earth tester's performance. As mentioned earlier, many of the modern electrical calibrators utilize synthesized resistance methods, to provide literally millions of different output values that thoroughly check ohms functions on 6.5 digit DMMs. A limitation of calibrators using the synthesized method is their inability to handle high currents. They are quite suitable for DMMs and analog volt/ohm meters, but cannot withstand the hundreds of milliamps earth testers source.

A solution was implemented using a matrix of discrete resistors so 3.5 digits of resistance output variability can be provided, using real resistors that can withstand the power. The calibrator was designed to accommodate three- and four-pole earth resistance testers, as well as two-terminal ohmmeters. Figure 6 shows how a typical, three-pole earth resistance tester is connected to the calibrator.

Ground/earth bond testers

Another category of safety testers that posed unique design challenges are ground bond testers. Ground bond testers are used by electricians and manufacturing engineers to verify the exposed metal of electrical appliances and consumer goods (powered by line ac voltage) are properly grounded to their chassis. In the event a fault current occurs inside the appliance, the user could potentially be electrocuted if the appliance is not properly grounded to its chassis.

Manufacturing of electrical goods requires a ground bond test as specified by certification bodies such as CE in the EU, UL in the USA and CSA in Canada. Without a CE, CSA or UL mark a product cannot be sold in

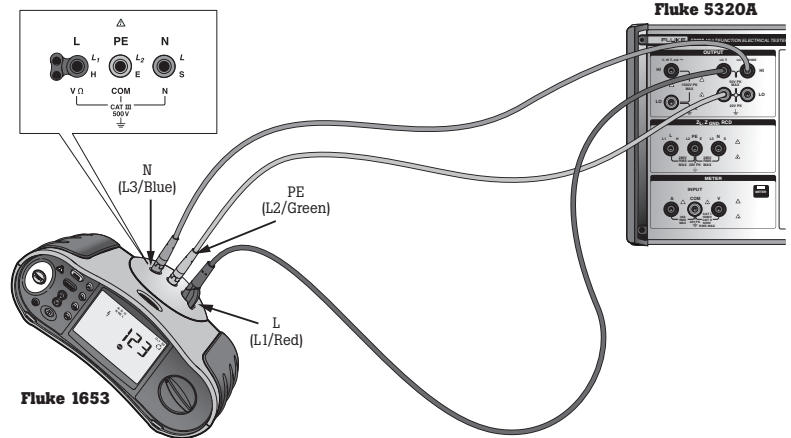

Figure 6. Testing a three-pole earth resistance tester with the calibrator [5].

that respective country. Besides mandatory ground bond testing during manufacturing, annual testing is required in some parts of the world as specified by national electrical testing regulations (typically in countries using 220 V to 240 V). Annual testing of appliances is one more step to assure the safety of humans.

Figure 7 shows a block diagram of the protection devices in an appliance. The appliance in figure 7 has several levels of protection in the form of (1) fuses, (2) insulation between the live circuit and metal chassis and (3) an earth grounded metal chassis. If there is a fault current due to defective internal insulation, the resistance between the metal chassis and earth ground should be less than 0.1 Ω to ensure the fuses will blow, keeping the operator safe. [6]

The ground bond tester simulates a fault condition by stimulating the appliance metal chassis and the earth ground connection point with current in

the range of 1 A to 30 A. Ground bond testers work under the Ohm's law principle. They measure the voltage drop between the protective earth power line connection and a test point on the metal chassis. The resulting resistance measurement is calculated by knowing the voltage drop and the applied current.

The difficulties in designing a calibrator for ground bond testers were to provide repeatable low value resistors capable of withstanding high current levels to 30 A and 40 A. The matrix array of discrete resistors could not be used because the 30 A current would have required a very large number of high current relays that would not have fit inside the calibrator. Instead, the design approach was to carefully study calibration procedures for ground bond testers. As a result, the calibrator has 16 discrete resistors ranging from 25 mΩ to 1.8 kΩ to cover these needs. The best-case uncertainty of these resistors is 5 mΩ.

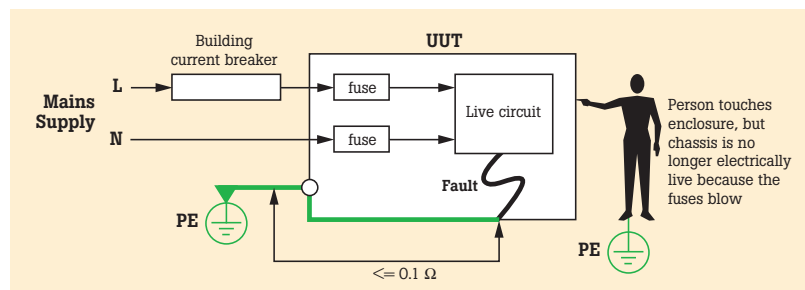

Figure 7. Appliance current fault protection.

Installation testers

Another category of testers which provided interesting design challenges were installation testers. These testers are not as common in countries that utilize 120 V mains, but are becoming increasingly common in countries that have 230 V mains, particularly in Germany, Spain, and the UK, including the British Commonwealth countries. The requirement for installation testing is driven by IEC 60364, developed in 1969, which provides guidance for developing national wiring. European nations came out with equivalents to IEC 60364 that ultimately resulted in the creation of a new class of electrical safety testers that carry out the stringent tests imposed by the International Electrotechnical Commission (IEC). Table 1 is a listing of the specific standards for various countries^[7].

Two common functions of these testers are to measure the loop and line impedance of an electrical branch circuit, and to verify the performance of mains protection circuits. The earth loop impedance test measures the resistance of the path a fault current would take between line and protective earth. This testing is needed to ensure that under fault conditions, the impedance is low enough to actually allow enough current flow to trip protective devices like circuit breakers. The loop measurement results in a calculation of the prospective short circuit current (PSC), an important parameter to know because it relates to the amount of current a circuit breaker and other protective equipment are able to interrupt in the case of a fault^[8]. Installation testers typically have PSC measurement ranges of 10 kA and 50 kA. Fortunately, from the calibrator designer's perspective, PSC is a calculated value using the formula $I = V_n / Z_s$ where V_n is the nominal line voltage and Z_s is the value of earth fault loop impedance. For accurately checking the installation tester, the calibrator ideally should have a

stable V ac source (to check the voltage measurement capability of the tester) and accurate, variable resistors (to check its resistance measurement capability).

The measurement of the loop impedance is made with the supply on, which posed another set of challenges for the calibrator designers. The measurement of line impedance (i.e. the impedance from line to neutral) is conducted similarly as the loop impedance measurement. The loop/line testers have measurement ranges of 0 to 2,000 Ω , in some cases up to 10,000 Ω , with typically 10 m Ω resolution.

The challenges the calibrator designers faced were to provide repeatable low ohm resistors that can handle up to 30 A in a circuit configuration that is safe for the user, since the resistors are part of a live mains circuit. Like the ground bond resistors, the matrix array of discrete resistors could not be used because the 30 A current would have required a very large number of high current relays that would not have fit inside the calibrator. Instead, the design approach was to carefully study the resistance values dictated by the electrical standards and the

installation testers designed to test those standards. As a result, the calibrator has 16 discrete resistors ranging from 25 m Ω to 1.8 k Ω to cover these needs. The best-case uncertainty of the calibrator is 5 m Ω . Block diagrams of the calibrator loop and line circuits are shown in Figure 8.

Country	National Regulatory Standards (based on IEC 60364)
Austria	OVE/ONORM E8001
Belgium	A.R.E.I / R.G.I.E
Denmark	Staerkstrombekendtgorelsen 6
Finland	SFS 6000
France	NF C 15-100
Germany	DIN VDE 0100
Italy	CEI 64-8
Netherlands	NEN 1010
Norway	NEK 400
Portugal	HD384
Spain	UNE 20460
Sweden	SS 4364661 / ELSAK-FS 1999:5
Switzerland	NIN / SN SEV 1000
UK	BS 7671 / 16th Edition IEE Wiring Regulations

Table 1. Various associated national equivalent standards are published throughout Europe. They specify the requirements for fixed electrical installations in buildings.

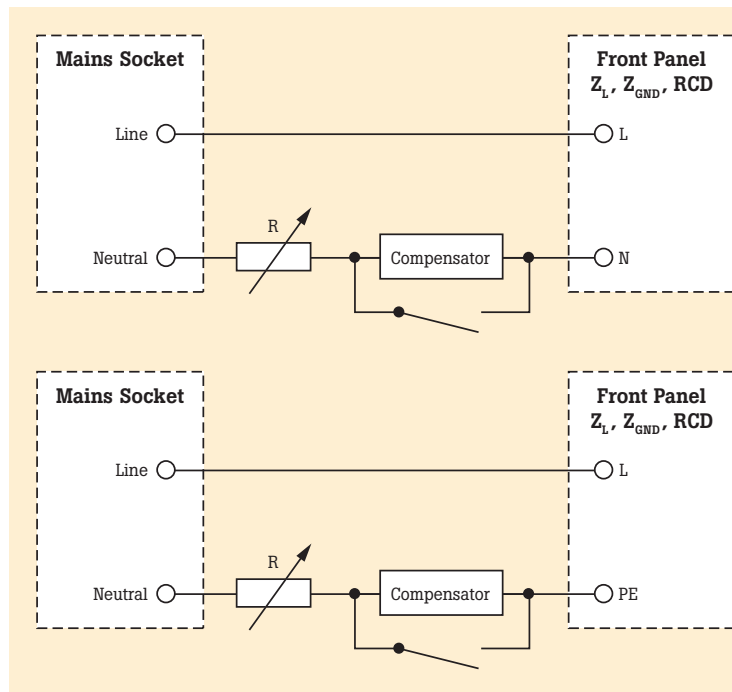

Figure 8. Loop and line circuit block diagrams of the Fluke 5320A Electrical Tester Calibrator.

The calibrator must provide these resistors in a live mains output, as the installation testers must test live mains as mentioned above. As shown in the block diagram, the calibrator inserts a selectable resistance in series with either the mains neutral and the output connector labelled "N", or the mains neutral and the output connector labelled "PE". Conceptually, this is simple enough, except in the real world there are additional resistances not shown in the block diagram, resulting from the mains-to-calibrator power cord, printed circuit board traces, and relay contacts. Components were chosen carefully to give repeatable results (< 5 mΩ). A different, larger line cord was even needed to ensure a low enough internal impedance.

The testers themselves can measure down to 0 Ω. One dilemma the designers faced was how to provide a 0 Ω source, given every mains circuit has finite resistance. The calibrator designers came up with a novel electronic compensator circuit based on synthesized resistor technology that effectively nulls out any parasitic resistances in the above circuits, thus giving a 0 Ω source.

Mains circuit protection devices such as residual current devices (RCD) and ground fault interrupters (GFI) are also tested by these installation testers. RCDs work on the current balance principle—all of the current from line (L) must return on neutral (N), otherwise, there is a fault in the circuit. As

shown in Figure 9, typical RCDs are built with a toroidal transformer, so that if equal currents are flowing on L and N, a signal is not induced on the detection circuits. For example, if a fault occurs and current flows to earth, the L and N currents will no longer be balanced. A flux is induced in the transformer and a current will flow in the secondary winding, activating the protection circuitry to trip the power^[9].

The electrical safety testers must provide fault currents of various waveforms as dictated by the regulatory standards (based on IEC 60364) to verify the RCD trips for a given current, or in a given time. These currents are shown in Figure 10^{[6],[10]}.

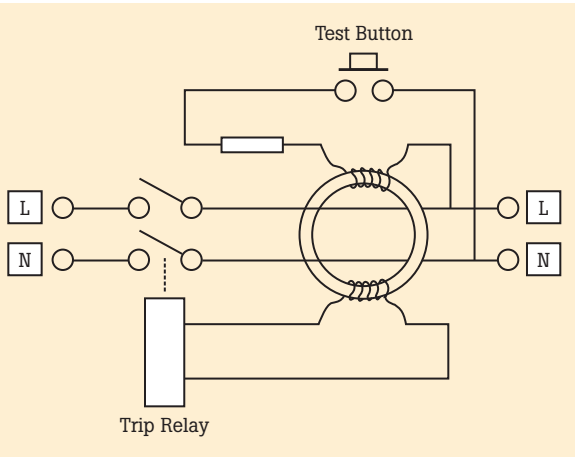

Figure 9. Block diagram of a typical RCD.





-  Positive symmetrical ac current (SYMP)
-  Negative symmetrical ac current (SYMN)
-  Positive pulse of dc current (POS)
-  Negative pulse of dc current (NEG)

Figure 10. Fault current shapes that a RCD tester must provide.

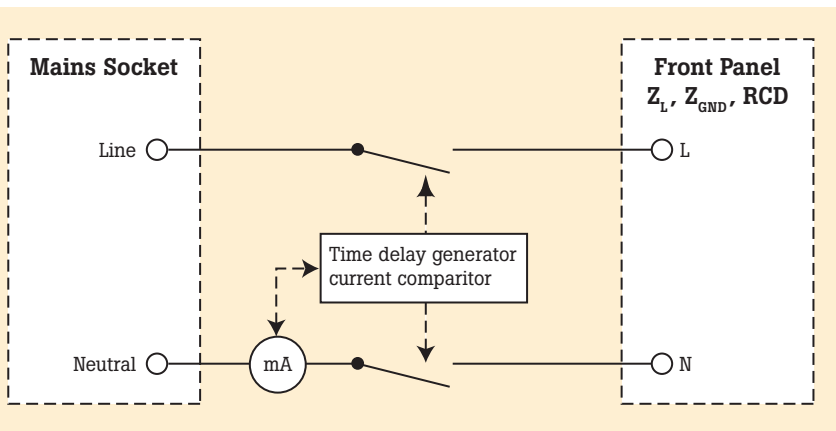

Figure 11. The block diagram of the RCD function in the calibrator. [5]

The calibrator checks RCD testers by incorporating a function that acts as a highly accurate RCD, with variable trip time and trip current. Besides having to react correctly to the various waveforms, the calibrator also had to behave properly for the "delayed response" modes of the S type (time delay) RCDs. Here, the installation testers provide a 30-second delay between the pre-test and the actual test.

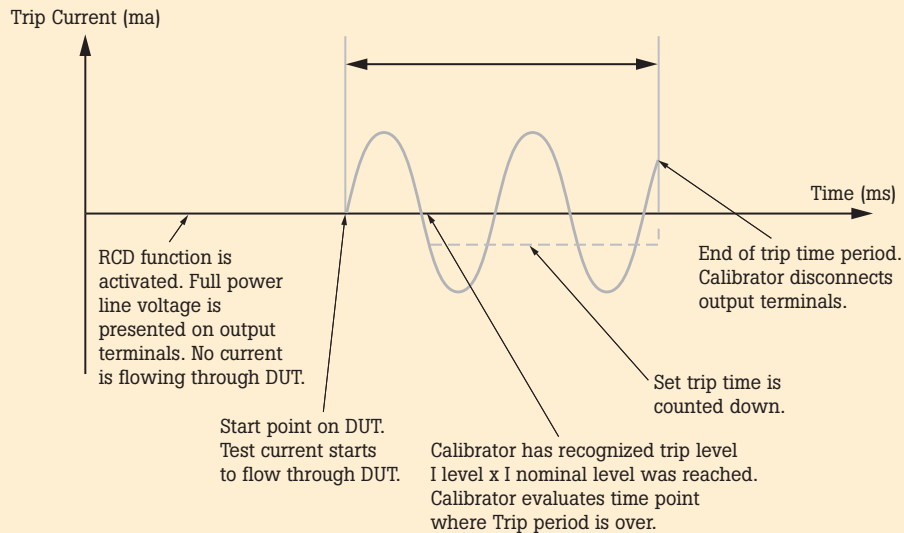

Figure 12. Timing of the RCD calibrator, which acts as a highly accurate, variable RCD.

The calibrator has circuits to sense the stimulus current coming from the installation tester, and to react accordingly based on the waveshape. Figure 12 shows the various parts of the waveform and the corresponding response of the calibrator^[6].

One problem while calibrating RCD testers is that the calibration equipment can trip current breakers in the building. To resolve this problem in the past, calibrations needed to take place on an unprotected network. Working on an unprotected network imposes safety hazards. The design of the Fluke calibrator allows calibration of RCD testers over protected networks without tripping the current breakers in the building.

Conclusion

Unlike traditional dc and low frequency calibrators, a calibrator for electrical safety devices must span a much wider breadth of voltages, currents, and resistance. The testers themselves can source and measure up to 30 A, measure resistors down to several mΩ using 30 A stimuli, all the way up to 10 TΩ with

5 kV stimuli. The electrical safety calibrator must provide accurate, stable outputs for all of these parameters. It must also provide a multitude of functions to cover the basic eight tests that this workload covers:

1. Earth resistance (3-pole and 4-pole)
2. Ground bond resistance
3. Continuity
4. Insulation resistance
5. High voltage dielectric breakdown
6. Leakage current (earth, direct/touch, differential and substitute)
7. Loop and line impedance
8. Residual current device verification

The challenges the designers faced were numerous, particularly for the engineers who have designed dc and low frequency ac calibrators for general purpose test instruments like digital multimeters and oscilloscopes, none of which have Ohm's law implementations above 20 V or so. A different mindset was needed for proper component selection, as well as clever design techniques to handle the wide range of voltages and currents the electrical safety testers deploy.

References

1. *Obtaining More Accurate Resistance Measurements Using the 6-wire Ohms Measurement Technique*, Thomas Schwertner, Keithley Instruments white paper
2. *Isolation and Safety Standards for Electronic Instruments*, National Instruments' white paper
3. *Resistive Load Boxes f or Hipot Testers and Megohmmeters*, QuadTech Application Note
4. *Getting Down to Earth*, Megger application note
5. *Fluke 5320A Electrical Tester Calibrator Operator Manual*
6. *Ground Bond Testing per UL 80950*, QuadTech application note
7. *Basic electrical installation testing*, Fluke application note
8. *The importance of loop impedance testing*, Fluke application note
9. IDC Plugs Limited, <http://www.powercords.co.uk/howrcd.htm>
10. *Testing RCDs with the Fluke 1650 Series*, Fluke application note

Fluke. Keeping your world up and running.™

Fluke Corporation
PO Box 9090, Everett, WA USA 98206

Fluke Europe B.V.
PO Box 1186, 5602 BD
Eindhoven, The Netherlands

For more information call:
In the U.S.A. (800) 443-5853 or
Fax (425) 446-5116
In Europe/M-East/Africa +31 (0) 40 2675 200 or
Fax +31 (0) 40 2675 222
In Canada (800)-36-FLUKE or
Fax (905) 890-6866
From other countries +1 (425) 446-5500 or
Fax +1 (425) 446-5116
Web access: <http://www.fluke.com>

©2006 Fluke Corporation. All rights reserved.
Specifications subject to change without notice. Megger is a registered trademark of Megger Groups Limited.
Printed in U.S.A. 12/2006 2755808 A-EN-N Rev A
Pub_ID: 11165-eng Rev 01